



19 THOMAS • IRVINE, CA 92618 • USA

Manufacturers of pH & O₂ Sensors
for Science and Industry

ORDER DESK & TECHNICAL SERVICE

Telephone:

1-888 pH PROBE (747-7623)
(949) 829-5555

FAX:

(949) 829-5560

Broadley-James®

DynaProbe® pH Sensors

Designed with a

Patented Solid State REFERENCE HALF-CELL

For use in all industrial process pH
measurement applications.

SENSOR SPECIFICATIONS

pH Range: 0 - 14 pH

Bulb Glass:* HT-3 (industrial grade)
HT-4 (high pH > 12.0)
GP (flat bulb)

Temperature Range:* 0 - 140°C

Pressure Range:* 50 - 300 psig

Signal Cable: Low Noise Coax,
Dual Shielded

* varies depending upon Model selected

PREPARATION FOR USE:

1. Remove storage boot containing the storage solution (3.8 Molar KCl) by unwinding the black sealing tape from the sensor housing.

NOTE:

DO NOT remove the wetted fiber pack from inside the storage boot.

2. Save the storage boot with fiber pack for future use as a storage container and bulb protector when sensor is not in service. Be certain to use 3.8M KCl (BJC P/N: AS-3120-C20-0500) as the storage solution. Seal boot to sensor with black electrician's tape using 3 to 5 complete wraps.

3. *For first-time use after removing the storage boot:* Inspect the sensor for any signs of breakage or shipping damage and commence with Calibration Procedures.

4. *For sensors with replaceable O ring seals:* All O rings require proper lubrication. We recommend use of **PARKER O LUBE** or equal for this purpose. Follow the instructions provided with lubricant. For best results we recommend that all O rings be replaced whenever sensor is removed for service or inspection.

CAUTION:

Hand-tighten only! It is not necessary to apply excessive torque to achieve a liquid tight installation. Severe twisting of the sensor housing could cause internal damage. If necessary, use a wrench for removal only! For valve retractable sensors, refer to SA857/SA858 and SA864 **Service Manuals** for assembly, installation, and complete service instructions.

CALIBRATION PROCEDURE:

Refer to the specific instructions for pH sensor calibration described in the instruction manual provided with the host pH instrument. These instructions will include procedures for automatic and/or manual calibration. The DynaProbe is designed to work with all quality pH instruments.

For best results it is recommended to perform a two point pH calibration using two pH buffer solutions in accordance with ASTM Method D1293, "Standard Test Methods for pH of Water".

Recommended Two Point Calibration:

1. Rinse the DynaProbe thoroughly with D.I. water to remove all traces of storage solution, process medium, or previous test solution to prevent "carry over" contamination of the pH buffer test solutions. Thoroughly rinse the DynaProbe with D.I. water after each buffer test.

2. Insert the DynaProbe in 7.0 pH buffer solution and momentarily stir with sensor to ensure proper contact. Allow up to 10 minutes for integral T.C. device to thermally equilibrate with the buffer solution before taking a pH reading. The pH reading should be 7.0 pH ± 0.33 pH (±20 mV) @ 25°C. Make necessary adjustment to the pH meter with the "standardize" or "zero" control for a pH indication = 7.0 pH.

3. Rinse the DynaProbe with D.I. water and insert in a 4.01 pH buffer solution. Stir with sensor to ensure proper contact. Allow up to 10 minutes for the integral T.C. device to thermally equilibrate with the buffer solution before taking a pH reading. Make any necessary adjustments to the pH meter with the "slope" or "span" control for a reading = 4.01 pH units.

NOTES:

- Always use "fresh" pH buffer solutions for best results.

- pH buffer solutions above 7.0 pH are less stable and have a very limited life. These high pH buffers will more readily absorb CO₂ from the atmosphere and will typically change to a lower pH value when left open.

- Keep in mind the the "older" a sensor becomes, it will exhibit slower response times and will become less efficient in terms of its ability to span several pH units with the same repeatability.

d.) pH sensors are imperfect devices and require "calibration" from time to time in order to be properly characterized to the host pH meter.

GRAB SAMPLE CALIBRATION:

1. Grab sample calibration of a pH sensor is more valid when the sensor has been previously "characterized" to its pH meter via the two point pH buffer calibration procedure. The grab sample technique will evaluate the pH sensor's performance under actual operating conditions which differ from the pH buffer calibration conditions previously seen by the sensor.

2. For a proper grab sample technique, a known good laboratory pH sensor and pH meter that are in calibration with each other are required equipment. The laboratory pH sensor should be exposed to the grab sample at the identical temperature that the on-stream pH sensor encounters in service to prevent the introduction of an "error" introduced by the solution-temperature-effects on accurate pH measurements.

3. No two pH sensors are identical, therefore, exact pH readings are rarely achievable. The on-stream pH sensor has been conditioned to the process environment and may be more correctly reporting the process pH than a laboratory pH sensor which has not yet totally acclimated to the process conditions.

4. The grab sample should be taken as physically close to the on-stream pH sensor as possible to ensure that a "representative" sample is being taken. The pH readings should be compared immediately. If required, adjust the on-stream pH meter to match the reading of the grab sample pH meter. Avoid any time lag between the grab sample pH reading and the calibration adjustment of the on-stream pH meter.

CLEANING A DynaProbe® WITH IMPAIRED RESPONSE:

Used pH sensors which are physically intact can sometimes be restored to an improved level of performance. All pH sensors have a given useful life span depending on the conditions of use. One of the following procedures may prove helpful in restoring a used pH sensor.

1. **Initial Cleaning:** Wash with a solution of liquid detergent or enzyme detergent and warm water by gently scrubbing with a soft toothbrush or soft tissue. Follow with thorough rinse in D.I. or clean tap water.

2. **Inorganic Scale Deposits:** Dissolve the deposit by immersion of the sensor's measurement tip in *dilute* hydrochloric acid for a few minutes. Repeat step #1 above.

DynaProbe® is a registered trademark of Broadley-James Corporation, Irvine, CA 92618 USA.

3. **Organic Oil or Grease Films:** Perform initial cleaning procedure. If film is known to be soluble in a particular organic solvent, wash with this solvent. Repeat step #1 above. Depending on the extent of the oil or grease contamination, it's possible that the liquid junction may be damaged beyond recovery. Soak in 3.8M KCl solution for a minimum of 30 minutes before recalibration and returning sensor to service.

4. **Plugged or Dry Liquid Junction:** Remove any observed contaminant with one of the above procedures, then soak in 3.8M KCl solution for a minimum of 30 minutes.

NOTES:

- Never permit the pH sensor to dehydrate or dry-out. Always keep it in a wetted environment especially when not in service.
- Cracked or broken sensors are not repairable.
- Inspect cable and connector to ensure that the insulation integrity is intact and that there are no signs of corrosion or contaminants on the metal components.

STORAGE:

1. **Short Term:** Immerse sensor measurement tip and liquid junction surface areas in 3.8M KCl. If this solution is not available, use 4.01 pH buffer, clean tap water, or lastly, a sample of the process being measured to keep the sensor hydrated.

2. **Long Term:** Fill storage boot that the sensor was originally shipped in with a freshly prepared 3.8M KCl solution and insert sensor. Seal boot to sensor with black electrician's tape using 3 to 5 complete wraps. The sensor should be stored in an upright (vertical) position.

ION TRAP DESIGN:

The unique solid-state reference half-cell with the ion trap design is shown in the cut away and exploded views of a DynaProbe sensor. The migration of contaminating ions from the sample stream into the reference half-cell of a pH sensor initiates the primary cause for premature sensor failure. Poisoning ions are trapped and prevented from reacting with the Ag-AgCl internal, thus prolonging sensor life while providing more precise pH measurements.

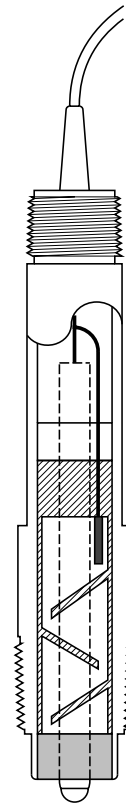

Cut Away View
of a Model ST873
DynaProbe® pH Sensor
with the Patented Solid-
State Reference Half-Cell

Exploded Views of a DynaProbe® pH Sensor
with the Patented Solid-State Reference Half-Cell

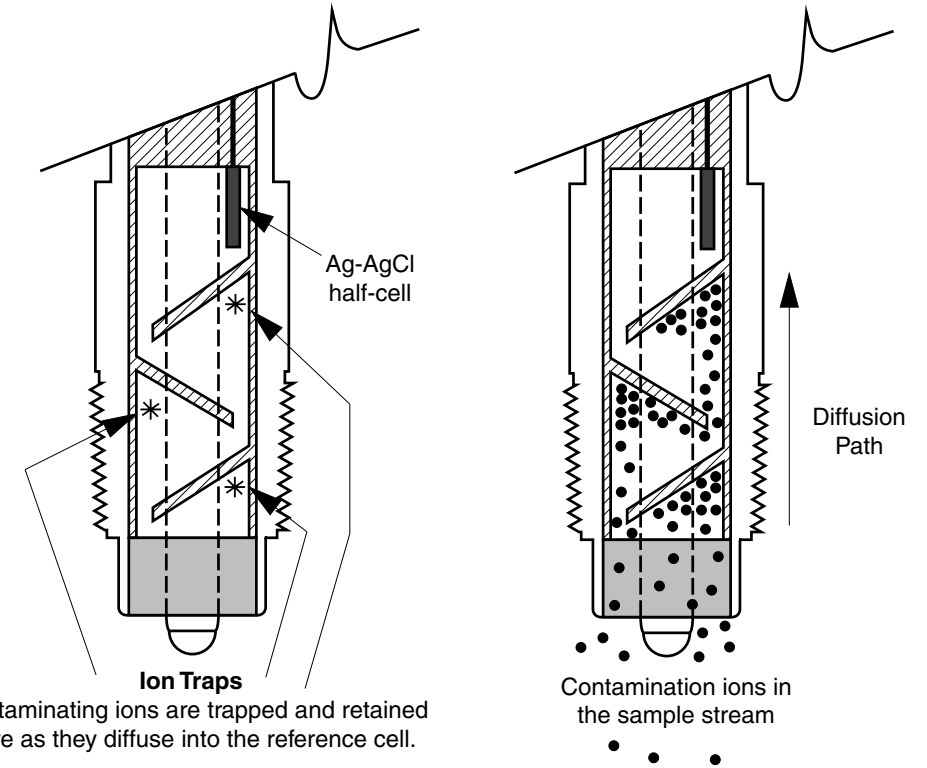

Ion Traps
Contaminating ions are trapped and retained here as they diffuse into the reference cell.

U.S. Patent 5,147,524

SENSOR SELECTION:

The DynaProbe® sensors are available in a wide variety of configurations to complement the requirements of any pH measurement application. Insertion, submersion, flow-through, and valve retractable designs are available. Selection of the proper design configuration along with the correct automatic temperature compensator, solution ground, cable, and connector features will provide the user with a more successful and trouble free pH measurement.

Models ST851 & ST951 Models ST873 & ST973 Models ST856 & ST956

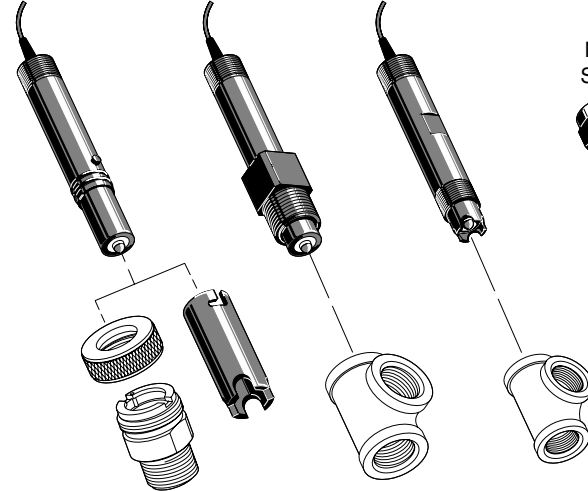

Model SA857

Model SA864

Model ST857

Model ST864

